



Physics 30

Self Assessment Study Guide

Revised: May 2003

Introduction

The objective of this self assessment package is to test your knowledge level of Physics 30. The program comprises the following topics:

- Unit 1: Linear momentum
- Unit 2: Vibration and waves
- Unit 3: Sound
- Unit 4: Electrical charges and electric field
- Unit 5: Electrical potential, electrical energy, and capacitance
- Unit 6: Electrical current
- Unit 7: DC circuits
- Unit 8: Magnetism
- Unit 9: Light, geometric optics
- Unit 10: Nuclear physics and radioactivity
- Unit 11: Nuclear energy

At the beginning of each unit, you will find a list of the learning objectives. Following is a list of the formulas you needed to solve the practice problems. The solutions to all the practice problems are found at the end of the Study Guide in the “Answer Key”.

After practicing by solving problems in each unit, you may take the self assessment test to verify your understanding of Physics 30. Success on this exam is required in order to take a placement exam at SAIT.

If you find that you need to review some topics, you can refer to your Physics 30 notes or text books such as Giancoli “PHYSICS” 5th Edition.

Unit 1: Linear Momentum and Impulse

A) Unit Objective:

- 1-1 Define momentum and its relation to force [Refer to problem: 1]
- 1-2 Solve impulse problems [Refer to problems: 2, 4]
- 1-3 Study elastic collision problems using energy and momentum conservation [Refer to problems: 3, 5, 6, 7]
- 1-4 Solve inelastic collision problems [Refer to problems: 8, 9, 10]

B) Formulas:

Momentum: $\mathbf{p} = m\mathbf{v}$

$$\sum \mathbf{F} = \frac{\Delta \mathbf{p}}{\Delta t}$$

Conservation of momentum: $m_1 v_1 + m_2 v_2 = m_1 v_1' + m_2 v_2'$

Impulse: $\mathbf{F} \Delta t = \Delta \mathbf{p}$

Elastic Collision: $\frac{1}{2} m_1 v_1^2 + \frac{1}{2} m_2 v_2^2 = \frac{1}{2} m_1 v_1'^2 + \frac{1}{2} m_2 v_2'^2$
 $v_1 - v_2 = -(v_1' - v_2')$

Inelastic Collision: $v = \frac{m + M}{m} \sqrt{2gh}$

C) Exercise problems:

- 1) Calculate the momentum magnitude of a 750 kg car moving with a speed of 90 km/h.
- 2) Calculate the impulse magnitude delivered to a football when it is kicked with a force of 1100 N. Assume that $\Delta t = 5.5 \times 10^{-2}$ s.
- 3) A car (1) of mass= 1000 kg traveling at speed of 75 km/h strikes another car (2) traveling with a speed of 45 km/h in the same direction. Both cars sticks together and move with a speed of 57 km/h. determine the mass of car (2).
- 4) An object of mass 0.45 kg initially at rest is struck with another object with an average force of 250 N. The first object's speed after collision was 2.8 m/s, what is the time of contact between the two objects?

- 5) An atomic nucleus initially at rest emits an alpha particle at a speed of 2.5×10^5 m/s. If the alpha particle has a mass of 4.0 u, and the original nucleus had a mass of 232 u. What is velocity of the new nucleus? [u (atomic mass unit) = 1.6605×10^{-27} kg]
- 6) An object of mass 0.25 kg is moving with a speed of 6.0 m/s, collides head-on and elastically with another object initially at rest. After collision, the first object has bounced backward with a speed of 4.0 m/s. Calculate the velocity and mass of the second object.
- 7) An object of mass 65 g is moving with a speed of 14 m/s collides head-on with a stationary object of mass 115 g. Assume that the collision is elastic, what is the speed of each object after collision?
- 8) A rail road car of mass 15000 kg moving with a speed of 3.5 m/s, collides and couples with other two rail road cars, each of same mass of 15000 kg and moving in the same direction with a speed of 1.5 m/s. Calculate: (a) the speed of the three cars after collision, and (b) the energy lost during collision.
- 9) A bullet of mass 13.0 g is fired into a stationary wooden block of mass 5.25 kg resting on frictionless surface. The bullet will be impeded in the block and will move with a speed of 0.750 m/s after collision. Determine the original speed of the bullet.
- 10) In problem No. 9, determine the height the block will reach after collision.

Unit 2: Vibration and waves

D) Unit Objective:

- 2.1 Solve simple harmonic motion problems [Refer to problems: 1, 2, 3, 4, 5, 6, 7, 8, 9]
- 2.2 Calculate simple pendulum frequency and time [Refer to problem: 7]
- 2.3 Calculate wave velocity frequency and wavelength in different medias [Refer to problems: 10, 11, 12, 13]
- 2.4 Calculate the energy transported by waves [Refer to problem: 14]
- 2.5 Solving standing waves problems [Refer to problems: 15, 16]

2 Formulas:

SHM

$$F = -kx$$

$$f = \frac{1}{T} = \frac{1}{2\pi} \sqrt{\frac{k}{m}} \qquad T = 2\pi \sqrt{\frac{m}{k}}$$

$$v_0 = 2\pi f A = A \sqrt{\frac{k}{m}}$$

$$v = \pm v_0 \sqrt{1 - \frac{x^2}{A^2}}$$

$$E = \frac{1}{2}mv^2 + \frac{1}{2}kx^2 = \frac{1}{2}mv_0^2 = \frac{1}{2}kA^2$$

$$x = A \cos \frac{2\pi}{T} t = A \cos 2\pi f t$$

$$v = -v_0 \sin \frac{2\pi}{T} t = -v_0 \sin 2\pi f t$$

$$a = -a_0 \cos \frac{2\pi}{T} t = -a_0 \cos 2\pi f t \qquad a_0 = A \frac{k}{m}$$

Simple Pendulum

$$T = 2\pi \sqrt{\frac{L}{g}} \qquad f = \frac{1}{2\pi} \sqrt{\frac{g}{L}}$$

Waves

$$\text{Wave velocity} \qquad v = \frac{\lambda}{T} = \lambda f$$

Wave on a string $v = \sqrt{\frac{F_T}{m/L}}$

Wave velocity in solids $v = \sqrt{\frac{E}{\rho}}$

Wave velocity in fluids $v = \sqrt{\frac{B}{\rho}}$

Energy transported by waves

$$\frac{I_2}{I_1} = \frac{r_1^2}{r_2^2} \qquad \frac{A_2}{A_1} = \frac{r_1}{r_2}$$

Standing waves

$$L = \frac{n\lambda_n}{2} \qquad f_n = nf_1 \qquad f_1 = \frac{v}{2L}$$

3 Exercise problems

- 1) Calculate the spring constant that is compressed for 3.5 cm when a mass of 1.50 kg is suspended on it.
- 2) When a 75.0 kg person rides his car, the car spring compresses for 2.5 cm. calculate the distance the spring will compress if another person of mass 85.0 kg will ride the car.
- 3) When a 460 g mass is attached to a vertical spring, the spring stretches by 17 cm. What is the mass that if attached to this spring will result in an oscillation of a frequency of 1.5 Hz?
- 4) When a mass of 230 g is attached to a vertical spring, the spring stretched for a distance y. If the mass makes 85 oscillations in 40 s, calculate the value of y.
- 5) A 1.50 kg mass is attached to a spring of 25 N/m spring constant. This mass is displaced for 8.0 cm from equilibrium. Calculate the frequency and the period of oscillations.
- 6) A mass is oscillating in simple harmonic motion obeys the following equation:
 $x = (0.65m) \sin\left(\frac{3\pi}{5}t\right)$. Calculate: (a) the amplitude, (b) the frequency, and (c) the period.

- 7) In problem No. (6) determine the maximum velocity.
- 8) In problem No. (6) what is the displacement and velocity at $t= 2.0$ s.
- 9) In problem No. (8) what is the total, kinetic, and potential energy if the oscillating object is 0.25 kg.
- 10) Calculate the period and frequency of a pendulum which makes 65 oscillations in 100s.
- 11) Calculate the wave length of a wave which has a speed of 343 m/s in air if the frequency of this wave is 1500 Hz.
- 12) The radio AM frequency range is from 550 kHz to 1600 kHz, and the radio wave speed is 1.00×10^8 m/s . Calculate the wave length range.
- 13) Calculate the speed of longitudinal waves in brass
($E=100 \times 10^9$ N / m², $B = 80 \times 10^9$ N / m², and $\rho = 8.9 \times 10^3$ kg / m³).
- 14) A string of length of 60 cm and mass of 2.2 g, is under tension of 450 N, determine the speed of waves in it.
- 15) The intensity of a wave is 3.5×10^4 J / m² at a distance of 1200 m from the source. Calculate the intensity at a distance of 1750 m.
- 16) If the fundamental frequency of a string is 350 Hz, determine the frequency of the next three harmonics.
- 17) A string is under tension of 50 N, it's mass is 5 g and it's length is 1.5 m. Determine the frequency of the first three harmonics.

Unit 3: Sound

E) Unit Objective:

- 3.1 Calculating the speed of sound in different medias [Refer to problems: 1, 2, 3]
- 3.2 Calculate the intensity of sound [Refer to problems: 4, 5, 6]
- 3.3 Solving problems: Vibrating strings and air columns [Refer to problems: 7, 8, 9, 10, 11, 12]
- 3.4 Calculate interference of sound waves, and determine beats [Refer to problems: 13, 14]
- 3.5 Solve Doppler effect problems [Refer to problems: 15, 16]

F) Formulas:

Speed of sound = wave length \times frequency
 $v = \lambda \times f$

Speed of sound in air: $v = 331 + 0.60T$ (T in $^{\circ}\text{C}$)

Intensity level of sound: $\beta = 10 \log \frac{I}{I_0}$ dB

Standing waves in strings:

Fundamental or first harmonic: f_1 , $\lambda_1 = 2L$

First overtone or second harmonic: $f_2 = 2f_1$, $\lambda_2 = L$

Second overtone or third harmonic: $f_3 = 3f_1$, $\lambda_3 = \frac{2}{3}L$

($f_n = nf_1$, $\lambda_n = \frac{2}{n}L$ where $n = 1, 2, 3, \dots$)

Standing waves in tubes open at both ends:

Fundamental or first harmonic: f_1 , $\lambda_1 = 2L$

First overtone or second harmonic: $f_2 = 2f_1$, $\lambda_2 = L$

Second overtone or third harmonic: $f_3 = 3f_1$, $\lambda_3 = \frac{2}{3}L$

($f_n = nf_1$, $\lambda_n = \frac{2}{n}L$ where $n = 1, 2, 3, \dots$)

Standing waves in tubes open at one end:

Fundamental or first harmonic: f_1 , $\lambda_1 = 4L$

First overtone or third harmonic: $f_3 = 3f_1$, $\lambda_3 = \frac{4}{3}L$

Second overtone or fifth harmonic: $f_5 = 5f_1$, $\lambda_5 = \frac{4}{5}L$

$(f_n = nf_1$, $\lambda_n = \frac{4}{n}L$ where $n = 1,3,5,\dots$)

Doppler effect:

Source moving towards stationary observer: $f' = \frac{f}{(1 - \frac{v_s}{v})}$

Source moving away from stationary observer: $f' = \frac{f}{(1 + \frac{v_s}{v})}$

Observer moving towards stationary source: $f' = (1 + \frac{v_o}{v})f$

Observer moving away from stationary source: $f' = (1 - \frac{v_o}{v})f$

Source and observer moving: $f' = (\frac{v \pm v_o}{v \mp v_s})f$

C) Exercise Problems

- 1) Calculate the speed of sound in concrete ($E=20 \times 10^9 \text{ N/m}^2$, $\rho = 2.3 \times 10^3 \text{ kg/m}^3$).
- 2) Calculate the speed of sound in mercury ($B = 2.5 \times 10^9 \text{ N/m}^2$, $\rho = 13.6 \times 10^3 \text{ kg/m}^3$).
- 3) Calculate the water depth in a well if a stone is dropped into it and the splash sound is heard 1.2 s later; assume that outside air temperature is 35°C.
- 4) The intensity level of an airplane at idle power is 95.0 dB. Calculate the intensity of this sound.
- 5) If the intensity level of a sound source is 103 dB, how many sources of the same intensity are needed to reach the intensity level of 120 dB?
- 6) If a 55 dB stereo sound strikes an ear drum of a diameter of 8 mm, calculate the energy absorbed by the ear drum in one second.

- 7) Find the fundamental frequency of a stretched string of length 30 cm, mass 2.0 g, and the tension of 100 N.
- 8) The third harmonic frequency of a stretched string is 900 Hz. Calculate the length of the string if the speed of sound in the string is 150 m/s.
- 9) A pipe open at both ends has a length of 1.2 m. If the air temperature is 20°C, determine the frequency of the third harmonic.
- 10) In problem No. 9, calculate the third harmonic frequency if the pipe is closed at one end.
- 11) A pipe closed at one end has a length of 2.5 m, what is the frequency of the standing wave that has two antinodes?
- 12) In problem No. 11, determine the fundamental frequency.
- 13) Two sound sources of frequencies 255 Hz and 290 Hz, calculate the beat frequency.
- 14) Two sound sources have same frequency of 400 Hz, if a person is standing at a distance of 4.0 m from one source, what is his distance from the other source if he hears nothing?
- 15) A policeman using a speed detector which is sending sound waves of 65000 Hz, and receives the reflecting waves from a car moving away from him at speed of 30.0 m/s. Calculate the frequency of the received wave.
- 16) While standing at a railroad station, you hear the train horn of 500 Hz. If the train velocity is 120 km/h and the air temperature is 30°C. Determine the frequency you hear when the train is approaching you and when it is going away.

Unit 4: Electric Charges and Electrical Field

G) Unit Objective:

- 4.1 Solve problems in Coulomb's Law [Refer to problems: 1, 2, 3, 4, 5, 6, 7, 8]
4.2 Calculate the electric field due to single charge [Refer to problems: 9, 10, 11, 12]

4 Formulas:

Coulomb's law:
$$F = k \frac{Q_1 Q_2}{r^2} \quad \text{N}$$
$$(k = 9.0 \times 10^9 \text{ N.m}^2 / \text{C}^2)$$

or:
$$F = \frac{1}{4\pi\epsilon_0} \frac{Q_1 Q_2}{r^2} \quad \text{N}$$
$$(\epsilon_0 = \frac{1}{4\pi k} = 8.85 \times 10^{-12} \text{ C}^2 / \text{N.m}^2)$$

Electric Field:
$$E = k \frac{Q}{r^2} \quad \text{N/C} \quad (\text{single point charge})$$

Elementary Charge:
$$e = 1.602 \times 10^{-19} \text{ C}$$

5 Exercise problems:

- 1) Calculate the net charge of a system of 4.5×10^{10} electrons.
- 2) Calculate the number of electrons in a charge of $-45.0 \mu\text{C}$.
- 3) Two point charges separated by a distance of 1.20 m have a mutual force of 0.0300 N. Calculate the force if the distance between them became 25 cm.
- 4) Calculate the repulsive force between two protons that are 3.5×10^{-15} m apart.
- 5) A plastic ruler is charged by rubbing it with a piece of cloth, the net charge is $-100 \mu\text{C}$. Calculate the number of electrons this ruler got and the increase in its mass.
- 6) Three point charges located on the x-axis, A is $10 \mu\text{C}$ at $(-3.0 \text{ cm}, 0)$, B is $-5 \mu\text{C}$ at $(1.0 \text{ m}, 0)$, and C is $-10 \mu\text{C}$ at $(5.0 \text{ cm}, 0)$. Calculate the magnitude and direction of the electrostatic force at point B.

- 7) Three point charges located as follows: A is $-15\mu\text{C}$ at $(0, 5.0\text{ cm})$, B is $+15\mu\text{C}$ at $(0, -5.0\text{ cm})$, and C is $-10\mu\text{C}$ at $(10\text{ cm}, 0)$. Calculate the magnitude and direction of the force acting on the charge at point C.
- 8) Two point charges located on the x-axis one is $-7\mu\text{C}$ at the origin and the other is $+5\mu\text{C}$ at $(0.20\text{ m}, 0)$. Calculate the location of a third charge where it will experience equilibrium.
- 9) In problem No. 8, calculate the magnitude of the electric field at the location $(0.10\text{ m}, 0)$.
- 10) Calculate the magnitude and direction of the electric force on an electron in a uniform electric field of $5.0 \times 10^5\text{ N/C}$.
- 11) Two point charges of equal magnitude of charge are set 20 cm apart. If the resultant electric field at the mid point between them is 45 N/C , calculate the value of the charge.
- 12) Calculate the magnitude and direction of the electric field at one corner of a square, the length of its sides is 80 cm , if there is three charges of $-3.00\mu\text{C}$ at the other corners.

Unit 5: Electric Potential, Electric Energy, and Capacitance

A) Unit Objective:

- 5.1 Calculate the electrical potential and the potential difference [Refer to problems: 1, 2, 3, 4, 5]
- 5.2 Solve problems using the relation between electric potential and electric field [Refer to problems: 6, 7, 8]
- 5.3 Calculate the electric potential due to point charge [Refer to problems: 9, 10, 11]
- 5.4 Calculate the capacitance of a capacitor with an air gap [Refer to problems: 12, 13]
- 5.5 Calculate the capacitance of a capacitor with a dielectric [Refer to problems: 14, 15]

B) Formulas:

- | | |
|--|--|
| a. Electric potential difference | $V_{ab} = \frac{\Delta PE}{q} = \frac{W}{q}$ |
| b. Electric field | $E = \frac{V_{ab}}{d}$ |
| - Electric potential due to point charge | $V = k \frac{Q}{r}$ |
| - Capacitance of a capacitor | $C = \epsilon_0 \frac{A}{d}$
($\epsilon_0 = 8.85 \times 10^{-12} \text{ C}^2 / \text{N.m}^2$) |
| c. Charge on a capacitor | $Q = CV$ |
| - Capacitance with a dielectric | $C = K\epsilon_0 \frac{A}{d}$
(K= dielectric constant) |

C) Exercise problems:

- 1) Calculate the work required to move a charge of $-5.5\mu\text{C}$ from the positive plate to the negative plate of parallel plates which are charged by a 12 V battery.
- 2) Determine the magnitude of the positive charge which takes $+ 3.4 \times 10^{-5} \text{ J}$ to move between two parallel plates connected to a 12 V battery.

- 3) Calculate the speed of an electron in a TV tube after being accelerated from rest under the effect of a potential difference of 27 kV.
- 4) Calculate the potential difference required to bring a proton moving at a speed of 9.7×10^5 m/s to rest.
- 5) Calculate the speed of an electron which has energy of 1.5 keV.
- 6) Calculate the electric field strength between two parallel plates 1.5 mm apart if they are connected to a 240 V potential difference.
- 7) Two parallel plates are connected to a 120 V supply, the electric field between them is 4.5×10^5 V/m, determine the air gap between them.
- 8) Calculate the electrical potential of a charge of $+25 \mu\text{C}$, when moved for a distance of 3.5 cm in an electrical field of 4.5×10^5 V/m.
- 9) Calculate the value of the charge whose electric potential at a distance of 3.5 mm is 4.5×10^{-5} V.
- 10) A point charge of $+5.0 \mu\text{C}$ is placed on the x-axis at (5 m, 0) and another one of $-5.0 \mu\text{C}$ is placed at (-5 m, 0). Calculate the potential at the following points: (a) (2.5 m, 0), (b) (-2.5 m, 0), (c) (0, 2.5 m), and (d) (0, -2.5 m).
- 11) Two identical point charges of $5.0 \mu\text{C}$ originally at rest and 5.0 cm apart, calculate their speed when they are very far from each other (mass of each is $5.0 \mu\text{kg}$).
- 12) Calculate the value of the charge which will flow to a capacitor of $1000 \mu\text{F}$ when connected to a 6 V battery.
- 13) Calculate the capacitance of two rectangular plates ($3.0 \text{ cm} \times 15 \text{ cm}$) with an air gap of 1.0 mm.
- 14) In problem 13, what will be the capacitance if the gap is filled with paraffin ($K= 2.2$).
- 15) The capacitance of a capacitor is $25 \mu\text{F}$ with air gap. The capacitor is connected to a 24 V source and then disconnected, when the gap is filled with certain dielectric the potential across the plates became 8.0 V, determine the dielectric constant of the dielectric.

Unit 6: Electric Currents

A) Unit Objective:

- 6.1 Calculate the electrical Current [Refer to problems: 1, 2, 3, 6]
- 6.2 Solve problems in Ohm's Law [Refer to problems: 4, 5, 7]
- 6.3 Calculate the electrical Power of an electrical load [Refer to problems: 8, 9, 10, 11, 12]
- 6.4 Solve problems for Alternating Current loads [Refer to problems: 13, 14, 15, 16, 17, 18]

B) Formulas:

Electric Current: $I = \frac{\Delta Q}{\Delta t}$

Ohm's Law: $V = IR$

Electrical Power: $P = IV = I^2 R = \frac{V^2}{R}$

Alternating Current: $V = V_0 \sin 2\pi ft$ ($V_0 = \text{Peak Voltage}$)

$I = I_0 \sin(2\pi ft)$ ($I_0 = \text{Peak Current}$)

$$I_{rms} = \frac{I_0}{\sqrt{2}} = 0.707I_0$$

$$V_{rms} = \frac{V_0}{\sqrt{2}} = 0.707V_0$$

$$\text{Average power} = I_{rms}^2 R = \frac{V_{rms}^2}{R}$$

$$\text{Maximum Instantaneous Power} = I_0 V_0$$

$$\text{Minimum Instantaneous Power} = 0$$

C) Exercise problems:

- 1) Calculate the value of the charge passes to a battery during charging if the current is 13.2 A for 5.0 h.
- 2) If the charge of one electron is $1.60 \times 10^{-19} \text{ C}$, and there is a current of 2.5 A flowing in a wire, calculate the number of electrons passing any point in the wire per second.
- 3) If the cathode ray tube of a monitor is drawing a current of 10 A, determine the number of electrons which strikes the screen every second.

- 4) Calculate the voltage across a resistor of $1.0 \text{ k}\Omega$ if a current of 0.012 A will flow across this resistor.
- 5) A potential difference of 220 V will produce a current of 5.0 A into a heater element. What is the resistance of this element?
- 6) In problem no. 5, calculate the value of the charge which will pass through the resistor in 10 minutes.
- 7) A bird stands on a bare electrical transmission line which carries a current of 3200 A , if the resistance per meter of this wire is $9.4 \times 10^{-4} \Omega$. Calculate the voltage drop across the bird's feet which are 8.0 cm apart.
- 8) The power output of an electrical heater is 1.5 kW when connected to a 220 V source. What is the resistance of this element and the current flowing in it?
- 9) A $4.5\text{-k}\Omega$ resistor is rated at 0.5 W , what is the maximum voltage that can be applied to it?
- 10) Calculate the current flowing in a 60 W bulb when connected to a 220 V source.
- 11) In problem no. 10, what will be the current if the source is 120V ?
- 12) Calculate the efficiency of an electric motor of $\frac{1}{3} \text{ hp}$, if it draws a current of 3.1 A when connected to a 120 V source.
- 13) Calculate the peak voltage (V_0) and the peak current (I_0) in a resistor of $3 \text{ k}\Omega$ if the $V_{rms} = 120 \text{ V}$.
- 14) The peak voltage (V_0) of certain electrical source is 310 V , if it is connected across a 750Ω resistor, calculate the rms value of the voltage and the current.
- 15) If the peak value of an alternating current through a $2.0 \text{ k}\Omega$ resistor is 0.16 A , calculate the rms voltage across it.
- 16) If a heater element of $75\text{-}\Omega$ resistance is connected to an AC electrical source of 120 V , calculate the average power, the maximum instantaneous power and the minimum instantaneous power.
- 17) Calculate the maximum instantaneous power consumed by a 5 hp motor connected to 120 V source.
- 18) In problem no.17, calculate the peak voltage and peak current.

Unit 7: DC Circuits

A) Unit Objectives

- 7.1 Calculate the equivalent resistance of resistors connected in series and in parallel [Refer to problems: 1, 2, 4, 5, 6]
- 7.2 Solve a problem using Kirchhoff's rules [Refer to problem: 7]
- 7.3 Calculate the equivalent capacitance of capacitors connected in series and in parallel [Refer to problems: 8, 9, 10]
- 7.4 Perform calculation for circuits containing a resistor and a capacitor [Refer to problem: 11]

B) Formulas

- Equivalent resistance of resistors connected in series:

$$R_{eq} = R_1 + R_2 + R_3 + \dots$$

- Equivalent resistance of resistors connected in parallel:

$$\frac{1}{R_{eq}} = \frac{1}{R_1} + \frac{1}{R_2} + \frac{1}{R_3} + \dots$$

- EMF (\mathcal{E}) and terminal voltage (V_{ab}) of a battery:

$$V_{ab} = \mathcal{E} - Ir$$

- Kirchhoff's Rules:
 - At any junction point, the sum of all currents entering the junction must equal the sum of all currents leaving the junction.
 - The sum of the changes in potential around any closed path of a circuit must be zero.

- Equivalent capacitance of capacitors connected in parallel:

$$C_{eq} = C_1 + C_2 + C_3 + \dots$$

- Equivalent capacitance of capacitors connected in series:

$$\frac{1}{C_{eq}} = \frac{1}{C_1} + \frac{1}{C_2} + \frac{1}{C_3} + \dots$$

- RC circuits:

Voltage across a capacitor (C) when connected to a battery (\mathcal{E}) through a resistor (R):

$$V = \mathcal{E} (1 - e^{-t/RC})$$

Voltage across a capacitor (C) when discharging through a resistor (R):

$$V = V_0 e^{-t/RC}$$

($t = RC = \text{time constant}$)

C) **Exercise problems**

- 1) Calculate the equivalent resistor of five resistors each is $240\ \Omega$, if they are connected in series and in parallel.
- 2) Consider the following resistors: $750\ \Omega$, $850\ \Omega$, $950\ \Omega$, and $1050\ \Omega$, calculate the minimum and maximum resistance we can get from combining them together.
- 3) In problem 2, calculate the minimum and maximum currents, if the resistors are connected to a $24\ \text{V}$ supply.
- 4) Ten light bulbs connected in parallel across a $220\ \text{V}$ supply with leads of a total resistance of $0.75\ \Omega$. If each bulb has a current of $0.27\ \text{A}$, calculate the resistance of each bulb and the power dissipated in the leads.
- 5) In the shown circuit determine the current and voltage across each resistor.

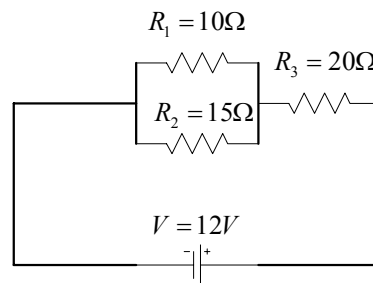

- 6) In the shown circuit, determine the current and prove that the voltage change around the circuit is zero.

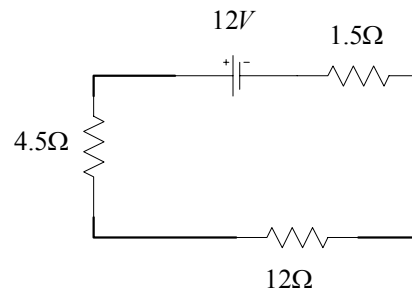

- 7) In the shown circuit, determine the current and voltage across each resistor.

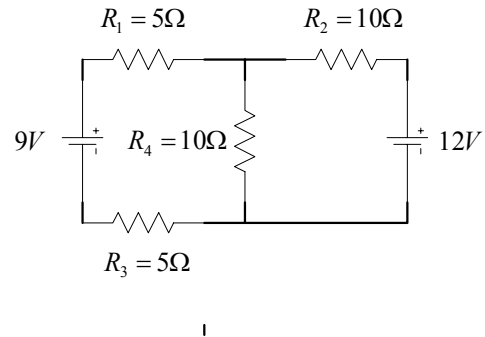

- 8) Calculate the equivalent capacitance of six capacitors of 5 μF, if they are connected in series and in parallel.
- 9) You have the following capacitors 1000 μF, 450 μF, and 0.15 mF. Calculate the minimum and maximum capacitance you can get from combining them together.
- 10) In problem 9, calculate the minimum and maximum energy stored, if the capacitors are connected to 220 V supply.
- 11) In a RC circuit, R= 250 Ω, C= 15 μF, and V= 12 V. Calculate: (a) the charge on the capacitor after 1.85 ms from closing the circuit, (b) the time constant of the circuit, (c) the maximum charge on the capacitor, and (d) the initial current in the circuit.

Unit 8: Magnetism

A) Unit Objective:

- 8.1 Calculate the force on an electric current in a magnetic field [Refer to problems: 1, 2, 3]
- 8.2 Calculate the force on an electric charge moving in a magnetic field [Refer to problems: 4, 5, 6]
- 8.3 Calculate the magnetic field due to a straight wire [Refer to problems: 7, 8, 9]
- 8.4 Calculate the force between two parallel wires [Refer to problems: 10, 11]

B) Formulas:

- Force on electric current in a magnetic field: $F = I l B \sin \theta$
 $F_{\max} = I l B \quad (\theta = 90^\circ)$

- Force on moving charge in a magnetic field: $F = q v B \sin \theta$

- Charge circular motion: $r = \frac{m v}{q B}$

- Magnetic field due to a straight wire: $B = \frac{\mu_0 I}{2 \pi r}$
($\mu_0 = 4 \pi \times 10^{-7} \text{ T.m / A}$)

- Force between two parallel wires: $\frac{F}{l} = \frac{\mu_0 I_1 I_2}{2 \pi L}$

C) Exercise problems:

- 1) Calculate the force per meter on a wire carrying a 10.0-A current if the angle with a magnetic field of 1.20 T is: (a) 30°, (b) 45°, (c) 60°, and (d) 90°.
- 2) Calculate the current flowing in a wire which is 2.25 m long, if the maximum force on it is 0.600 N when placed in a uniform magnetic field of 0.120 T.
- 3) A 2.25 m long wire of mass equals 0.45 kg is placed in a magnetic field of 0.120 T. What is the minimum current needed to levitate the wire?

- 4) Calculate the magnitude and direction of the force on an electron traveling at 2.50×10^5 m/s horizontally to the East in a vertically upward magnetic field of 0.95 T.
- 5) Calculate the magnetic field strength in a circular path of radius $r = 0.35$ m, that an alpha particle follows with at 1.25×10^7 m/s. ($m_{\alpha} = 6.69 \times 10^{-27}$, $q = 2e$)
- 6) The kinetic energy of an electron is 0.40×10^{-12} J. If the electron is moving in a magnetic field of 0.75 T perpendicular to its circular path. What is the radius of its path?
- 7) Calculate the magnetic field 15 cm away from a wire which carries 12.5 A current. What is the percentage of this field compared to Earth's magnetic field (0.55×10^{-4} T)?
- 8) Calculate the distance from a wire which carries a current of 12.5 A, where the magnetic field equals the Earth's magnetic field.
- 9) Two long parallel wires are supplying a 30 A to a motor. The wires are 5 mm apart. Determine the magnetic field midway between them.
- 10) Two vertical parallel straight wires 5 cm apart, the first is carrying a down current of 21 A and exerts a repulsive force on the second wire of 12.5×10^{-4} N/m. Calculate the magnitude and direction of the current in the second wire.
- 11) Three long parallel wires each is carrying a current of 12 A, all in the same direction. If the distance between each wire and the other is 25 cm (they are at the three corners of an equilateral triangle), calculate the magnitude force per unit length affecting each wire.

Unit 9: Light: Geometric Optics

A) Unit Objective:

- 9.1 Solve problems concerning reflection by a plane mirror [Refer to problems: 1, 2]
- 9.2 Solve spherical mirrors problems [Refer to problems: 3, 4, 5, 6, 7]
- 9.3 Use the index of refraction [Refer to problem: 8]
- 9.4 Use Snell's law to solve problems [Refer to problems: 9, 10]
- 9.5 Calculate the critical angle for total internal reflection [Refer to problems: 11]
- 9.6 Use the lens equation to solve problems [Refer to problems: 12, 13, 14, 15]

B) Formulas:

- a. The angle of incidence θ_i = the angle of reflection θ_r
- b. Spherical mirrors:

$$\text{Focal length of a mirror} \quad f = \frac{r}{2}$$

$$\text{Mirror equation} \quad \frac{1}{d_o} + \frac{1}{d_i} = \frac{1}{f}$$

$$\text{Lateral magnification} \quad m = \frac{h_i}{h_o} = -\frac{d_i}{d_o}$$

- Index of refraction: $n = \frac{c}{v}$
(c = speed of light in vacuum, v = speed of light in a given material)

- Refraction Snell's Law: $n_1 \sin \theta_1 = n_2 \sin \theta_2$

- Internal reflection: critical angle $\theta_c = \sin^{-1} \frac{n_2}{n_1}$

- c. Thin lenses:

$$\text{Power of a lens} \quad P = \frac{1}{f}$$

$$\text{Lens equation} \quad \frac{1}{d_o} + \frac{1}{d_i} = \frac{1}{f}$$

C) Exercise problems:

- 1) A man is 1.85 m tall stands 3.5 m from a plane mirror that extends vertically upward from the floor. His son who is 0.95 m tall stands 1.75 m away from the mirror. Determine the minimum height of the mirror so that the man can see his son completely in the mirror.
- 2) Two plane mirrors meet at one edge where the angle between them is 120° . If a light ray strikes one of them at 30° , at what angle the ray leaves the second mirror?
- 3) Calculate the radius of a concave mirror which focuses the sun rays at 25 cm in front of it.
- 4) Determine the distance of the image from a concave mirror. The mirror has a radius of 55 cm and the object is at 35 cm in front of it.
- 5) An object that is 50 cm high is located 2.5 m in front of a mirror of $f = -6.0$ m. Determine the location and height of the image and if it is up right or inverted.
- 6) Calculate the focal length of a convex mirror which has a magnification of +0.90 for an object which is 1.8 m from the mirror.
- 7) The image of a building is virtual and smaller in a curved mirror. The image is 16 cm behind the mirror. Determine what kind of the mirror is used and what its radius of curvature.
- 8) Calculate the speed of light in a medium whose index of refraction is 1.58.
- 9) Determine the angle of incidence of a light ray in ice, if the angle of refraction is 45° .
- 10) A beam of light in air strikes the surface of Plexiglas ($n=1.51$) and is partially reflected and partially refracted. If the angle of reflection is twice the angle of refraction, find the angle of incidence.
- 11) Calculate the critical angle between air ($n=1$) and water ($n=1.33$). What is the critical angle between air and Plexiglas ($n = 1.51$)
- 12) Calculate the object distance from a converging lens of focal length 75 mm, if the image is 85 mm behind the lens.
- 13) Determine the power and type of a lens with focal length of 75 mm.
- 14) Determine the focal length and type of a lens of -9.5 D.
- 15) In problem no. 14, if an object 1.0 cm high and 14 cm from it, determine the position, type, and height of the image.

Unit: Nuclear Physics and Radioactivity

A) Unit Objective:

- 10-1 Describe the structure and properties of the nucleus [Refer to problems: 1, 2, 3, 4]
- 10-2 Calculate the binding energy and the nucleus forces [Refer to problem: 5]
- 10-3 Describe the Alpha decay of a nucleus [Refer to problem: 6]
- 10-4 Describe the Beta decay of a nucleus [Refer to problem: 7]
- 10-5 Calculate the Half-life and rate of decay [Refer to problems: 8, 9]

B) Formulas:

- Nucleus radius: $r \approx (1.2 \times 10^{-15}) A^{\frac{1}{3}} \text{ m}$

- Atomic mass unit: $u = 1.6605 \times 10^{-27} \text{ kg}$
 $= 931.5 \text{ MeV} / c^2$

- Radioactive decay law: $N = N_0 e^{-\lambda t}$

- Decay rate: $R = \frac{\Delta N}{\Delta t} = \lambda N$

- Half-life time: $T_{\frac{1}{2}} = \frac{0.693}{\lambda}$

C) Exercise problems:

- 1) Determine A,Z, and N for the following isotopes: (a) ${}_{92}^{238}\text{U}$, (b) ${}_{94}^{239}\text{Pu}$, and (c) ${}_{60}^{144}\text{Nd}$.
- 2) Determine the mass of the α - particle (${}_{2}^4\text{He}$) in kg , u , and MeV / c^2 .
- 3 Calculate the radius of a ${}_{29}^{64}\text{C}$ nucleus.
- 4) Calculate the value of A of a nucleus whose radius is $3.7 \times 10^{-15} \text{ m}$.
- 5) Calculate the total binding energy of ${}_{7}^{14}\text{N}$.
($m_H = 1.007825u$, $m_N = 1.008665u$, nitrogen atomic mass = $14.003074 u$)
- 6) Write down the decay equation of ${}_{84}^{212}\text{Po}$ when it emits an α -particle, and calculate the energy released during this process.

- 7) Write down the decay equation of ${}_{11}^{22}\text{Na}$ when it emits β^+ , and calculate the energy released during this process.
- 8) The half-life of ${}_{92}^{238}\text{U}$ is 4.468×10^{18} yr, calculate the decay constant λ .
- 9) In problem 8, calculate the number of the remaining nuclei if the number of decays per second is 275.

Unit 11: Nuclear Energy

A) Objective:

- 11-1 Write the nuclear reactions equation. [Refer to problems: 1, 2, 3]
11-2 Calculate the energy of a nuclear fission [Refer to problems: 4, 5]
11-3 Calculate the energy of a nuclear fusion. [Refer to problem: 6]

B) Formulas:

- Reaction energy (Q value): $Q = (m_A + m_a - m_B - m_b)c^2$
- Threshold energy = $(1 + \frac{m_a}{m_A})|Q|$
(m_a = mass of incident particle, m_A = mass of the stationary particle)

C) Exercise problems:

1) Complete the following nuclear reactions:

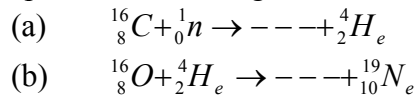

2) Calculate the Q-value of the following reaction:

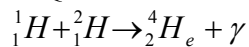

3) Calculate the threshold energy of the following reaction:

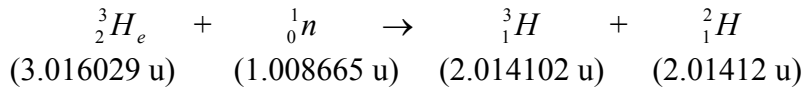

4) Calculate the energy released in the following reaction:

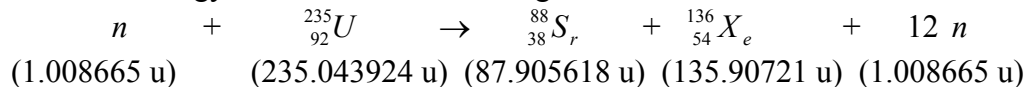

5) Calculate the ${}^{235}_{92}\text{U}$ quantity required to operate a 750 Mw reactor for one year, if the efficiency is 35%.

6) Calculate energy released in the following fusion reaction:

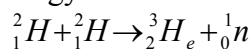

ANSWER KEY

Unit 1

- 1) 1.9×10^4 kg.m/s
- 2) 60.5 N.s
- 3) 1500 kg
- 4) 5.0×10^{-3} s
- 5) -4.4×10^3 s
- 6) 2 m/s, 1.25 kg
- 7) -3.9 m/s, 10 m/s
- 8) 2.2 m/s, 1.7×10^4 J
- 9) 304 m/s
- 10) 0.029 m

Unit 2

- 1) 420 N/m
- 2) 2.8 cm
- 3) 0.30 kg
- 4) 0.055 m
- 5) 0.65 Hz, 1.5 s
- 6) 0.65 m, 0.3 Hz, 3.3 s
- 7) 1.2 m/s
- 8) -0.38 m, 0.97 m/s
- 9) 0.19 J, 0.12 J, and 0.07 J
- 10) 1.5 s, .65 Hz
- 11) 0.229 m
- 12) 188 m to 545 m
- 13) 3.4×10^3 m / s
- 14) 110 m/s
- 15) 1.6×10^4 J / m²
- 16) 350 Hz, 700 Hz, and 1050 Hz
- 17) 40 Hz, 80 Hz, and 120 Hz

Unit 3

- 1) 2.9×10^3 m / s
- 2) 4.3×10^2 m / s
- 3) 7 m
- 4) 3.16×10^{-3} W / m²
- 5) 50
- 6) 1.59×10^{-11} W
- 7) 203 Hz
- 8) 0.25 m
- 9) 430 Hz

- 10) 210 Hz
- 11) 100 Hz
- 12) 34 Hz
- 13) 35 Hz
- 14) 4.4 m, 3.6 m
- 15) 54500 Hz
- 16) 550 Hz, 460 Hz

Unit 4

- 1) $-7.2 \times 10^{-9} C$
- 2) 2.81×10^{14} Electrons
- 3) 0.691 N
- 4) 18N
- 5) 6.24×10^{14} electrons, and $5.68 \times 10^{-16} kg$
- 6) 560 N to the left
- 7) 97 N vertically down
- 8) 1.2 m, 0
- 9) $1.1 \times 10^7 N/C$
- 10) $8.0 \times 10^{-14} N/C$
- 11) $2.5 \times 10^{-11} C$
- 12) $8.08 \times 10^4 N/C$, to the center along the diagonal

Unit 5

- 1) $6.6 \times 10^{-5} J$
- 2) $2.8 \mu C$
- 3) $9.7 \times 10^7 m/s$
- 4) 4900 V
- 5) $2.3 \times 10^7 m/s$
- 6) $1.6 \times 10^5 V/m$
- 7) $2.7 \times 10^{-5} m$
- 8) 0.39 J
- 9) $17.5 \mu C$
- 10) $+1.2 \times 10^4 V$, $-1.2 \times 10^4 V$, 0, 0
- 11) 950 m/s
- 12) 6 mC
- 13) 40 pF
- 14) 88 pF
- 15) $K=3$

Unit 6

- 1) $2.4 \times 10^5 C$
- 2) 1.6×10^{19} Electron
- 3) 6.2×10^{19} Electrons
- 4) 12 volts

- 5) 44Ω
- 6) 3000 C
- 7) 0.24 volts
- 8) 32Ω , 6.9 A
- 9) 4.7 V
- 10) 0.27 A
- 11) 0.5 A
- 12) 67%
- 13) 170 V, 0.06A
- 14) 219 V, 0.29 A
- 15) 230 V
- 16) 190 W, 380 W, 0 W
- 17) 10 hp
- 18) 170 V, 44A

Unit 7

- 1) 1200Ω , 48Ω
- 2) 220Ω , 3600Ω
- 3) 6.7 mA, 0.11 A
- 4) 807Ω , 5.5 W
- 5) R_1 : 0.28 A, 2.8 V
 R_2 : 0.18 A, 2.8 A
 R_3 : 0.46 A, 9.2 V
- 6) 0.67 A, $V_{4.5} = 3 \text{ V}$, $V_{12} = 8 \text{ V}$, $V_{1.5} = 1 \text{ V}$
- 7) R_1 : 0.2 A, 1 V
 R_2 : 0.5 A, 5 V
 R_3 : 0.2 A, 1 V
 R_4 : 0.7 A, 7 V
- 8) 0.83 μF , 30 μF
- 9) 100 μF , 1600 μF
- 10) 2.4 J, 39 J
- 11) 70 μC , 3.8 ms, 0.18 mC, 0.048 A

Unit 8

- 1) 6.0 N/m, 8.5 N/m, 10 N/m, 12 N/m
- 2) 2.22 A
- 3) 16.3 A
- 4) $3.8 \times 10^{-14} \text{ N}$, North
- 5) 0.75 T
- 6) $7.1 \times 10^{-3} \text{ m}$
- 7) $1.7 \times 10^{-5} \text{ T}$, 31 %
- 8) 4.55 cm
- 9) $4.8 \times 10^{-3} \text{ T}$
- 10) 14.9 A, down $4.8 \times 10^{-3} \text{ T}$

11) 2.0×10^{-4} N/m, away from the center of the triangle

Unit 9

- 1) 1.25 m
- 2) 10°
- 3) 50 cm
- 4) 1.3 m
- 5) 1.8 m behind the mirror, 0.36 m high, up right
- 6) - 16.2 m
- 7) Convex, 32 cm
- 8) 1.90×10^8 m/s
- 9) 70°
- 10) 82°
- 11) 49° , 41°
- 12) 64 cm
- 13) 13 D, converging
- 14) - 11 cm, diverging
- 15) - 62 cm, virtual, same side with object, 4.4 cm

Unit 10

- 1) (a): 238, 92, and 146. (b): 239, 94, and 149. (c) 144, 60, and 84
- 2) 6.644×10^{-27} kg, $4.0u$, and $3727 \text{ MeV} / c^2$
- 3) 4.8×10^{-15} m = 4.8 fm
- 4) 29
- 5) 104.7 MeV
- 6) ${}_{84}^{212}\text{Po} \rightarrow {}_{82}^{208}\text{Pb} + {}_2^4\text{He}$, 8.95 MeV
- 7) ${}_{11}^{22}\text{Na} \rightarrow {}_{11}^{22}\text{Ne} + \beta^+ + \nu$, 1.82 MeV
- 8) 4.91×10^{-18} s⁻¹
- 9) 5.60×10^{19} nuclei

Unit 11

- 1) ${}^6_{13}\text{C}$, ${}_0^1n$
- 2) 5.49 MeV
- 3) 4.36 MeV
- 4) 126.5 MeV
- 5) 820 kg
- 6) 3.27 MeV